

# **BONENG**



**RJT  
使用手册**

**RJT  
Use Manual**

中文

EN

09/2024

中文

# 目录

<b>重要提示</b>	01
<b>1.安全说明</b>	02
<b>2.技术说明</b>	02
2.1 铭牌说明	02
2.2 型号说明	03
2.3 噪声水平	05
2.4 温升标准	05
2.5 注意事项	05
<b>3.安装与拆卸</b>	06
3.1 安装前的注意事项	06
3.2 准备工作	07
3.3 减速机的整机安装	07
3.4 减速机空心轴的安装	09
3.5 减速机空心轴的拆卸	10
<b>4.安装方位</b>	10
4.1 安装方位的说明	10
4.2 安装方位页面的说明	10
<b>5.润滑/冷却/加热</b>	14
5.1 润滑油的选择	14
5.2 润滑油的注油量	14
5.3 润滑油的更换	15
5.4 加热	15
5.5 逆止机构	15
<b>6.使用</b>	16
6.1 润滑油添加	16
6.2 设备检查	16
6.3 起动	16
<b>7.检查与维护</b>	17
7.1 定期检查与维护	17
7.2 检查与维护的周期	17
7.3 检查与维护的注意事项	17
<b>8.故障处理</b>	18
<b>9.售后服务</b>	19

## 重要提示

在安装操作过程中，  
请注意本说明书中的安全提示和警告提示！



有电危险  
可能产生的后果：死亡或者严重伤害



危险情况  
可能产生的后果：轻微伤害



有害情况：  
可能产生的后果：损坏传动装置和环境



使用建议和有用的信息



遵守本手册的规定可以让装置无故障运行，同时也满足质量缺陷索赔的要求，因此在使用传动装置进行工作之前，请您先阅读本说明书；

本说明书包含重要的安装维护提示，请将说明书保管在靠近设备的位置，以便安装维护参阅；

# 1 安全说明

安全说明主要涉及减速机的使用。当使用减速机时，请注意说明书中的相关安全提示！

使用手册为本公司所供减速机的有机组成部分。

减速机的安装、操作、维护和修理人员均需认真阅读本说明书并遵守其中的规定。

严格遵循说明书中的规定是实现产品无故障运行和履行任何质量保证要求的必要条件。

在遵循说明书规定的前提下还要注意：

相关安全和事故防范的国家（地区）规定；

相关设备的特别规定和要求；

设备装置上的安全警告和安全标志牌。

下列情况会导致人身伤害和财产损失：

使用不当；

安装或操作失误；

违反规定拆除必要的防护罩或机壳。

若因违反本说明书的规定而造成的任何损伤或停机，本公司概不负责。

为不断追求技术进步，我们保留对其进行修改的权力。通过不断改进，将在保持基本特性的基础上，有利于进一步提高其使用性能和工作安全性。

## 2 技术说明

### 2.1 铭牌说明

⊕ <b>BONENG</b> ⊕	
Type	
n <sub>2</sub>	RPM
P <sub>1</sub> kW	T <sub>2</sub> N · m
n <sub>1</sub> RPM	i
Oil	Wt. kg
NO.	Date
⊕ ⊕	

产品型号  
输出转速  
(直联马达时才有)  
额定输入功率 kW  
(直联马达时指马达功率)  
额定输出扭矩 N · m  
额定输入转速 RPM  
(直联马达时是指马达转速)  
公称减速比  
润滑油粘度  
重量  
产品编号  
出厂日期

铭牌上的数据十分重要，请仔细阅读，并保持其整洁，当需要服务时，请提供铭牌上的产品编号、使用时间及故障类型。

## 2.2 型号说明

### 2.2.1 R系列

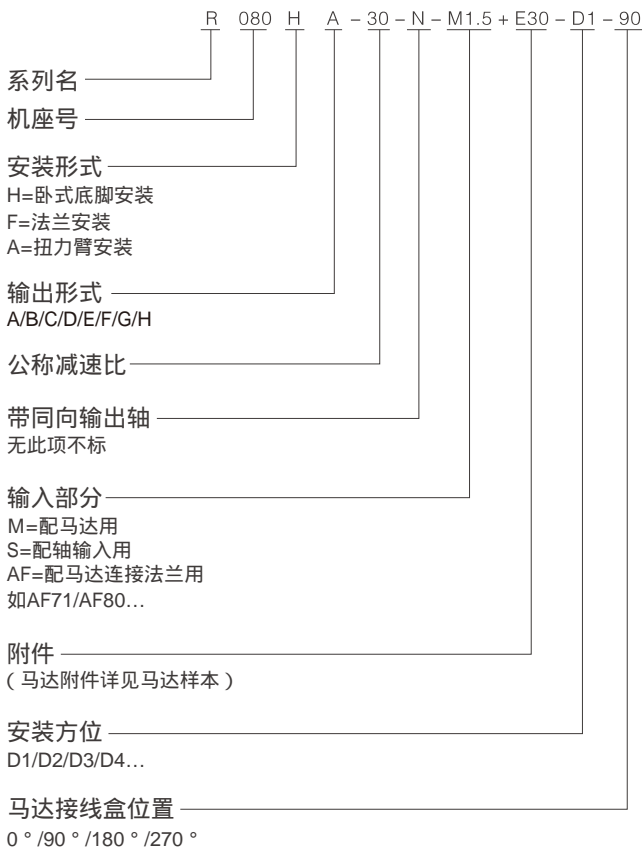

## 2.2.2 J系列

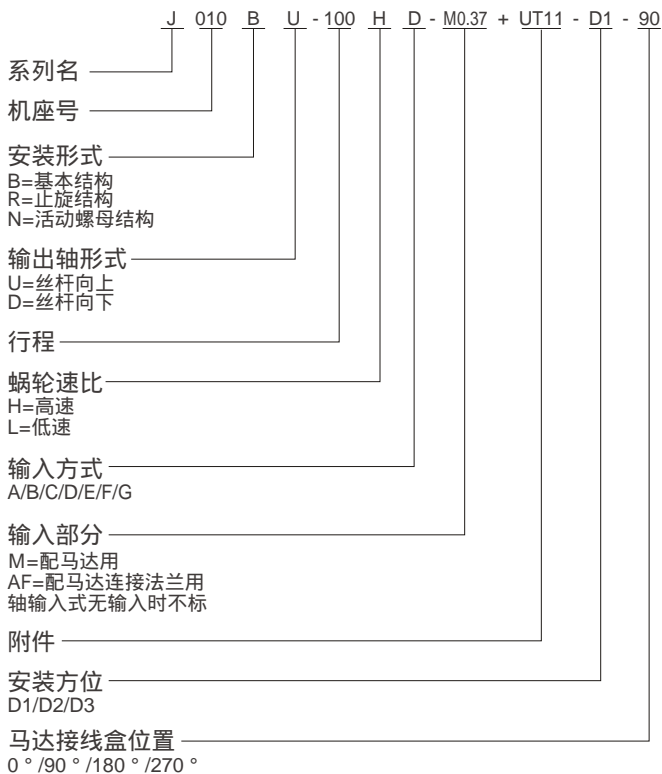

## 2.2.3 T系列

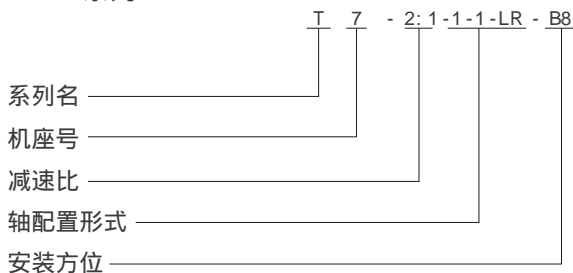

型号说明仅供用户参考使用，特殊供货类别另请咨询；

## 2.3 噪声水平

关于在距离减速机的距离为1m处测量减速机的噪声水平的情况，噪声的水平指的是当减速机在热机状态下、在铭牌上标注的输入转速为 $n_1$ 、输入功率为 $P_1$ 时的噪声水平。如果标注了几个数字的话，则其中最高的转速和功率适用。噪声功率级见表1。

表1 噪声功率级

单位：dB(A)

电动机极	R	J	T
4、6、8极	73	72	73

## 2.4 温升标准

减速机运转时产生的温升不大于表2的规定，且油池最高温度不超过90。

表2 油池温升

单位：

电动机极数	负载形式	R	J	T
4、6、8极	空载	42	40	42
	负载	44	42	44

## 2.5 注意事项(下述注意事项与减速器的使用有关):

运输减速机时,应防止撞击轴端,在吊运减速机时,不得将吊环螺钉挂在轴端处的螺纹。

当储存减速机 and 任何单独的零部件的时候一定要做好防锈措施,以免生锈;储存时不得将减速机叠放在一起;减速机应该放置在不振动的干燥木制基座上,并做好防尘防水措施。

对于储存时间较长(1~2年)的减速机,在进行定期包装检查情况下,同时还应检查机械清洁度、机械损伤和防锈层是否完好。

减速机不得在强酸、强碱、低温、高温、潮湿、重度的空气污染及具有化学物品的场所内储存或工作。(除订货合同中有特殊规定外)。

减速机工作环境温度 $-10 \sim +40$ 。(除订货合同中有特殊规定外)。  
减速机应在许用转矩范围使用,超扭矩使用应在输出轴上装安全装置,以免减速机损坏。

减速机适用于连续运转(J系列升降机除外),并允许正反两向运转。(配逆止器时除外)。

若出现安装方位变动,一般情况下调换油镜、油塞、通气帽即可。

减速机一定不能用高压清理设备清洁。



对减速机进行安装、维护、检修时都必须在减速机不工作的情况下进行。如果在减速机的运行过程中发现了任何异常现象(例如过热或者不正常的噪声等)，应该立即停机检查，必要时请与博能公司联系。

在减速机上不得进行焊接工作，也不得用作焊接工作的接地点。焊接会造成精密齿轮和轴承的不可修复的损坏。

凡是旋转的零部件必须配备合适的防护罩以防止人员的意外接触,例如联轴器,液力偶合器,齿轮,驱动皮带轮等。

必须遵守减速机上所附加的说明，例如铭牌、箭头指示方向的警示牌等；这些铭牌和标记上面不得有灰尘和油漆。

在组装或者解体工作中损坏了的螺栓一定要用同等强度和类型的新螺栓更换。

根据减速机的操作条件，减速机的表面、润滑油和零部件可能会达到相当高的温度，小心烫伤！

当更换润滑油的时候，要谨慎小心不要被热油烫伤。

安装J升降机时，台架面上的孔，在满足丝杆能方便通过的前提下，应尽可能小。

J升降机不可连续运转，负载时间不得超过20%ED（工作负载时间率）；且升降机在正常负载工作时，不可进行人为强行停机，否则将使升降机受到严重损坏；

零配件及备件一定要从博能公司购买，以免其他公司配件安装造成运行危险和不必要的机械损伤；

## 3 安装与拆卸

### 3.1 安装前的注意事项



确认减速机完好无损（在运输或储存过程中未损坏）；

确认现场环境条件与铭牌内容相符；

减速机环境温度为：-10 ~ +40 ；无油、酸、有害气体、蒸汽、放射性物质等；

特殊形式减速机：是根据环境条件配置的；



在户外安装时应该避免阳光的直射，一定要避免热力集中影响减速机的正常性能；

蜗轮减速机：不能对具有自锁功能的减速机施加过大的逆向外部惯性矩，以免损坏减速机。

## 3.2 准备工作

彻底清除输出输入轴和法兰表面的防腐剂、污物等；注意不要让溶剂浸入并损坏油封。

若减速机储存时间在一年以上，轴承内润滑剂的使用寿命将缩短。

工具/材料的准备：一组扳手、扭矩扳手、装配夹具、输入和输出紧固装置、润滑剂(防锈油)、密封螺栓的介质(螺纹锁固剂)。

## 3.3 减速机的整机安装

减速机只能按规定的安装位置安装在平的、减振的、刚性好的、抗扭的支撑结构上；同时也需充分考虑即使加上最大载荷不至于改变装配好后各部件的位置。

底座式安装应校准中心高；联轴器联接时应校准两轴的同轴度；柔性联轴器时浮动量不超过联轴器的允许范围；刚性连接时保证各安装联接的形位公差；长轴联接还要考虑轴的足够刚度。

底座式安装时应校准中心高：

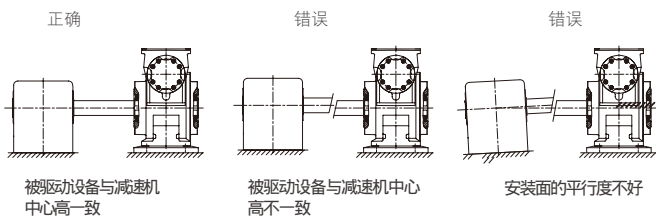

使用合适升降装置利用轴端螺纹孔，压入连接件，严禁直接使用锤子敲击。



避免不允许的径向力(皮带轮、链轮安装)：

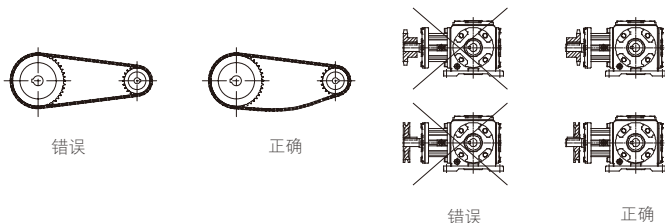

避免负载受力不均；

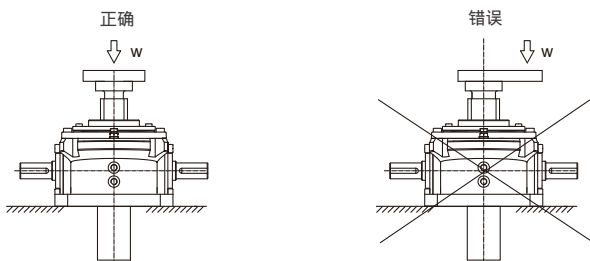

安装联轴器时应该校正下列各点：

a) 最大和最小间距

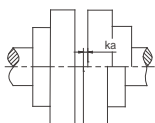

b) 角度偏差

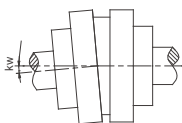

c) 轴线偏差

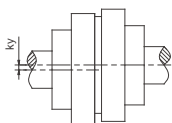

法兰式安装，凸肩（或凹肩）应配合良好，以免错位；

正确

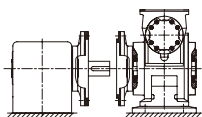

安装止口应保证足够的同心度

错误

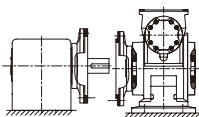

联轴器与安装法兰的同心度不好

错误

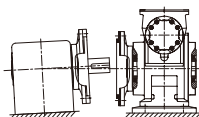

法兰安装面与连接轴的垂直度不好



如果您事先使用润滑剂涂抹到输出部件上，或者短时间加热（到 +80 ~ +100 ），就可以轻松地进行装配。  
在减速机上安装驱动零件时（如联轴器、齿轮、链轮等），如果需要预加热，则必须保护好轴上的油封，要用隔热屏减少热辐射。



皮带轮、小齿轮和联轴器等输出部件的安装绝对不能用锤子敲击的方法套装到轴端上，否则有可能损伤轴承、外壳及轴；请使用套装夹具及轴端部带有螺纹孔的中心孔进行装配。  
安装皮带时请注意皮带的正确张紧力（按照制造方的规定）。

### 3.4 减速机空心轴的安装

减速机空心轴与被驱动设备的实心轴连接时,应清理干净并涂防锈油(空心轴一定要精密对中)。除了在图中所示的螺母和螺杆的方法安装以外,还可以使用其它类型的装置安装,例如液压提升装置等。

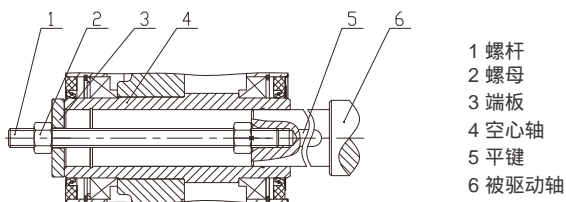

安装螺栓一般情况下采用8.8级,如果有高温或者振动冲击等情况,请在螺纹连接处作好防松措施。各个紧固螺栓的拧紧扭矩见下表:

螺栓大小 (mm)	预紧力矩 (N · m)	螺栓大小 (mm)	预紧力矩 (mm)
M6	15	M30	2000
M8	36	M36	3560
M10	72	M42	5720
M12	123	M48	8640
M16	295	M56	13850
M20	580	M64	14300
M24	1000	M72	20800



使用添加有溶剂的清洁剂时,要采取充分的通风措施,有可能要注意溶剂的着火危险性。  
传动和输出元件譬如皮带轮,联轴器等必须有接触保护盖板!

## 3.5 减速机空心轴的拆卸

### 空心轴的拆卸

请松开固定螺栓，并拆下压板和孔用弹性挡圈；  
 请将辅助板、防松螺母安装在被驱动轴和孔用弹性挡圈之间，拧入固定螺栓后将被驱动轴拆开。

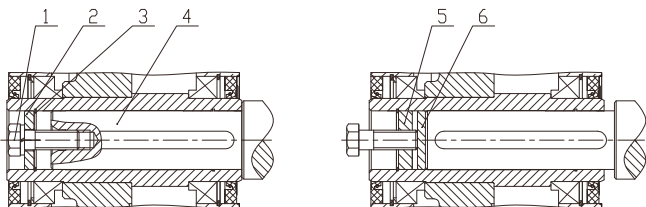

1. 固定螺栓  
2. 压板

3. 孔用弹性挡圈  
4. 被驱动轴

5. 防松螺母  
6. 辅助板



注：

辅助板和防松螺母不在供货范围内。(空心轴端螺纹孔的分布和大小请参照BONENG公司技术图纸)

## 4 安装方位

### 4.1 安装方位的说明

减速机的具体安装方位及选型可参见BONENG公司产品选型手册。

### 4.2 安装方位页面的说明

减速机的安装方位页面中使用的图形符号及其含义：

图形符号		含义	
		通气帽	进油孔
		油 镜	
		放油孔	

R050~080方箱体

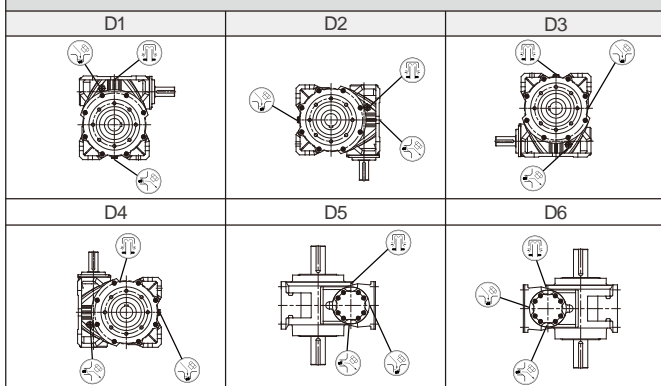

R050~080圆箱体

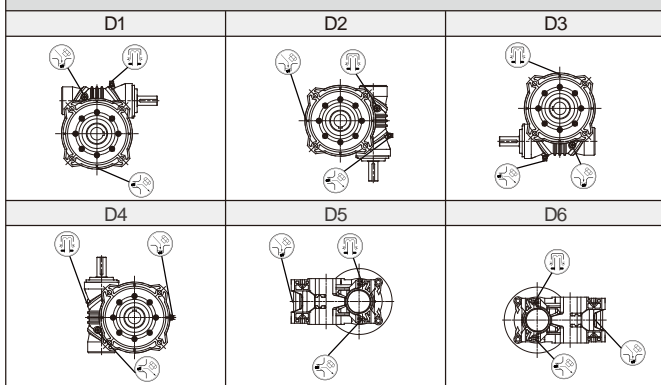

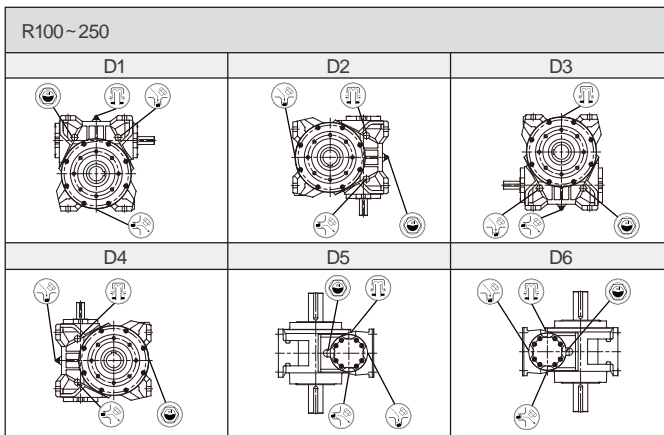

#### 4.2.1 J系列丝杆升降机的安装方位

J010~1000 (J010~150出厂时已加极压润滑脂,无油镜)

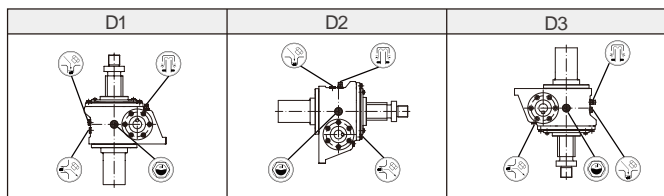

#### 4.2.2 T系列螺旋锥齿轮转向箱的安装方位

T06~T25-1-../U../D../1-1-../U-D.. (ARA1/ARA2/ARA4/T04出厂时已加000#锂基脂,无油镜)

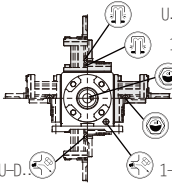
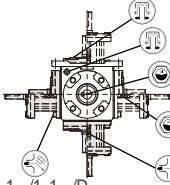
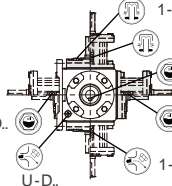
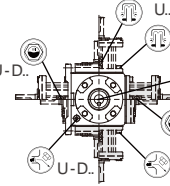
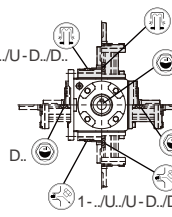
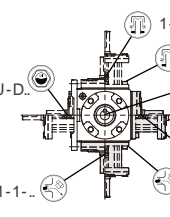
B3	B8
 <p>U../U-D.. 1-../1-1-../D.. U../U-D../D.. 1-../1-1-.. D../U-D.. 1-../1-1-../U..</p>	 <p>D../U-D.. 1-../1-1-../U.. U../U-D../D.. 1-../1-1-.. U../U-D.. 1-../1-1-../D..</p>
B6	B7
 <p>1-../1-1-.. U../U-D../D.. 1-../1-1-.. D../U-D.. U../U-D.. 1-../1-1-../U../D.. U-D..</p>	 <p>U../U-D../D.. 1-../1-1-.. U../U-D.. 1-../1-1-.. D.. U-D.. 1-../1-1-../U../D..</p>
V5	V6
 <p>U../U-D../D.. 1-../1-1-.. D../U-D.. 1-1-.. 1-../U../U-D../D..</p>	 <p>1-1-.. U../U-D../D.. U../U-D.. 1-../1-1-.. D.. 1-../1-1-.. U../U-D../D..</p>



1-LR-... 1-UD-... U-LR-... D-LR-... 1-1-LR-... 1-1-UD-... U-D-LR-...  
 为不同类型输入/输出轴的配置形式(每种类型有6种,共42种)  
 用户可根据实际安装需求选型,必要时请向博能公司技术部门咨询。



## 5 润滑/冷却/加热

### 5.1 润滑油的选择

在相同粘度等级和类型的前提下，您可以自由地选择国际知名品牌的润滑油。如需改变推荐的粘度等级敬请垂询。

下表列出了博能使用润滑油的选择。

产品系列	适用产品规格	润滑油(脂)牌号	环境温度
R	R050~R080	000#极压润滑脂	-10 ~+40
	R100~R250	VG680(蜗轮蜗杆油)	-20 ~+50
T	T01~T04	000#极压润滑脂	-10 ~+40
	T06~T16	VG220(重负荷工业齿轮油)	-20 ~+40
	T20/T25	VG320(重负荷工业齿轮油)	-20 ~+40
J	J010~J150	000#极压润滑脂	-10 ~+40
	J200~J1000	VG220(蜗轮蜗杆油)	-20 ~+40



环境温度低于-10 时必须使用合成油。

为确保产品的使用寿命，实际使用中推荐使用合成油。

使用环境温度超过上述范围时，请咨询BONENG公司技术部门。

### 5.2 润滑油的注油量

本注油量为建议值。根据减速机级数和速比的不同，相应加油量也不同。请注意油镜作为加油量多少的指示，油位必须在油镜的中间位置。

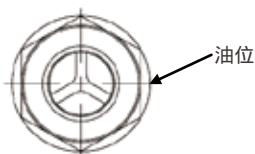

对于未设置或未安装油镜的产品类型，添加油量以产品样本说明为参考。

同一型号产品不同安装方位状态下，添加的油量也不相同。

下表列出了对于安装方位相应的润滑油注油量建议值。

### 5.2.1 R系列注油量参照(单位 :L)

型号 安装方位	R050	R063	R080	R100	R125	R160	R200	R250
D1、D3	0.1	0.2	0.38	1	8.1	15	30	51
D2、D4	0.12	0.25	0.46	1.2	10	18	33	57
D5、D6	0.04	0.6	0.12	0.4	3.3	5.5	9.4	17

### 5.2.2 J系列注油量参照(单位 :L)

型号 安装方位	J010	J025	J050	J100	J150	J200	J300	J500	J750	J1000
D1、D3	0.1	0.12	0.15	0.22	0.25	0.6	2.5	5.5	9.5	14
D2	0.1	0.12	0.15	0.22	0.25	0.5	2	4.5	7.5	8

升降机运行过程中丝杆（螺母）处需涂抹润滑脂）

### 5.2.3 T系列注油量参照(单位 :L)

型号 安装方位	ARA1	ARA2	ARA4	T04	T06	T07	T08	T10	T12	T16	T20	T25
B3/B8/B6 /B7/V5/V6	已注入	已注入	已注入	已注入	0.95	1.5	1.9	3.5	7	10	11	18

## 5.3 润滑油的更换

要用和原来的润滑油同一牌号、同一厂家的润滑油。更换润滑油品种时，要用润滑油将减速机箱体里面的沉积物、金属颗粒和残留的润滑油都冲洗干净。

## 5.4 加热

对标准减速机：使用环境温度 - 10 ~ +40 ，当环境温度低于 - 10 时需预热或空载启动，当减速机温度超过 - 10 时允许加载运行。

## 5.5 逆止机构

带逆止器的减速机：在安装或启动前，一定要检查传动装置的旋转方向，为防止错误的旋转方向，必要时请向技术部门咨询。逆止器为免维护。

## 6 使用

### 6.1 润滑油添加

本公司产品一般都未带润滑油出厂，在设备运行前请先按使用手册加润滑油。



在标记有该符号的位置上将通气帽拧出，给减速机加入润滑油。

### 6.2 设备检查

检查油面高度。

配备了止回装置的减速机，检查马达接线是否正确。

检查轴封是否有效。

检查旋转的零部件是否与其它零件接触。

### 6.3 起动

检查自由状态下转动方向是否正确（同时监听轴转动时是否有异常研磨噪声）。

运行检查时要保证轴上没有输出元件，同时开启相关的监测和保护设备。

无论什么时候，只要怀疑出现了不正常的运行现象（例如 温升、噪声、振动等异常），应立即关掉马达，并查明原因。

必要时与BONENG公司联系。

## 7 检查与维护

### 7.1 定期检查与维护

用户要定期对减速机进行维护和保养，要定期检查润滑油的使用状态，定期清理通气帽、风扇、冷却盘管和齿轮马达表面的灰尘和异物，保持减速机清洁，保证齿轮马达的正常运行。

### 7.2 检查与维护的周期

检查油温	每日
检查减速机的不正常的噪声	每日
检查油面高度	每月
检查减速机的漏油	每月
检验油中的水分	在400工作小时后,至少每年一次
在起动之后的首次换油	在400工作小时后
其后的换油	每5000工作小时,至少每年一次
清理通气帽	每3个月
清理减速机箱体	和换油同时进行
检查紧固螺栓的紧固程度	第一次换油后,其后每隔一次换油
对于减速机的全面检查	大约每2年和换油同时进行

### 7.3 检查与维护的注意事项

切断电源，防止触电，等待减速机冷却。

油位的检查：油位必须在油镜的中间位置。

油的检查：移去油塞，取油样,检查油的粘度指数；如果油明显浑浊，建议尽快更换。

油的更换：

不同的润滑剂禁止相互混合使用。

冷却后油的粘度会增大,放油困难,换油时齿轮箱应保持温热。

在油塞下面放一个接油盘,拆下油塞/通气帽,将油全部排除后装上油塞。

注入同牌号的新油,油量应与安装方位一致(见铭牌);若牌号不同则向我司售后服务咨询。

在油镜处检查油位，装上通气帽。

## 8 故障处理

故障	原因	措施
减速机的噪声变化	紧固件松动了	将螺栓/螺母拧紧到规定的扭矩。 更换损坏了的螺栓/螺母。
	减速机的齿轮发生了损坏	和售后服务部联系。 检查所有的齿轮，更换损坏了的零件。
	轴承间隙过大	和售后服务部联系。 调整轴承的间隙。
	轴承损坏	和售后服务部联系。 更换损坏的轴承。
工作温度过高	箱体里面的油面过高或过低	检查油面的高度，如果有必要的话，调整。
	油过于陈旧	和售后服务部联系。 检查上一次换油的时间，如果有必要的话就更换。
	油受到严重污染	和售后服务部联系。 换油
轴承处的振幅升高	轴承损坏	和售后服务部联系。 查阅操作人员在振动测量中所获得的数据。 检查并按需更换轴承。
	齿轮损坏	和售后服务部联系。 检查并按需更换齿轮。
减速机漏油	箱体盖或者连接处的密封不良	检查密封和连接处，如果必要的话，更换新的。将连接处密封好。
	径向轴封环失效	和售后服务部联系。 换新的径向密封。
油中有水	油中有杂物	用试管检查油的状态是否有水分存在。 实验室分析油。
	减速机受到机器间的通风过来的凉空气而产生凝霜	用合适的保温材料将齿轮箱保护起来。 关闭空气的出口或者在结构上改变其方向。

注：对于客户自己无法排除的故障请和我公司售后服务部联系。

## 售后服务

各种传动设备，客户发现有质量问题时，不要先拆卸零件，应说明以下情况然后与本公司售后服务部联系，说明现象后确认问题所在，再采用较理想的方法处理。

登录“www.boneng.com”

点击“服务”

点击“售后服务”



### 博能传动（沈阳）有限公司

控制器/驱动器：024-31271571  
马达/齿轮马达/齿轮箱：024-31292571

### 博能传动（天津）有限公司

控制器/驱动器：022-86928559  
马达/齿轮马达/齿轮箱：022-26929558

### 博能传动（开封）有限公司

控制器/驱动器：0371-23335230  
马达/齿轮马达/齿轮箱：0371-23277771

### 博能传动（潍坊）有限公司

控制器/驱动器：0536-4699687  
马达/齿轮马达/齿轮箱：0536-4699667

### 博能传动（长沙）有限公司

控制器/驱动器：0731-88386958  
马达/齿轮马达/齿轮箱：0731-88380725

### 博能传动设备（成都）有限公司

控制器/驱动器：028-87740066  
马达/齿轮马达/齿轮箱：028-87740066

### 博能传动（苏州）有限公司

控制器/驱动器 苏南区：0512-66182005  
马达/齿轮马达/齿轮箱 苏南区：0512-66189918  
控制器/驱动器 浙沪区：0512-66182005  
马达/齿轮马达/齿轮箱 浙沪区：0512-66189918  
控制器/驱动器 苏皖区：0512-66182005  
马达/齿轮马达/齿轮箱 苏皖区：025-52171612

### 博能传动（美国）有限公司

技术支持/调试/售后服务：  
1250 E 222nd Euclid, OH 44117, United States  
Email: America@boneng.com  
Tel: 1-216-618-3099 / 1-216-618-0138

### 博能传动（印度）有限公司

技术支持/调试/售后服务：  
Plot No. E-10/3, MIDC sinnar (Malegaon) Industrial Area,  
Nashik, 422123, Maharashtra, India.  
Email: india@boneng.com  
Tel: +91-11-4507 6293 / +91-22-2781 3385

### 其他地区

控制器/驱动器：0512-66182005  
马达/齿轮马达/齿轮箱：0512-66189918





# Contents

<b>Important notes</b>	21
<b>1.Safety information</b>	22
<b>2.Technical information</b>	23
2.1The name plate information	23
2.2Type instruction	24
2.3Noise level	26
2.4Temperature rising	26
2.5Notes	26
<b>3.Installation and dismantlement</b>	28
3.1Notes before installation	28
3.2Preparations	28
3.3Installation of gear unit	28
3.4Assembly of hollow shaft of gear unit	29
3.5Disassembly of hollow shaft of gear unit	31
<b>4.Mounting position</b>	32
4.1General description of mounting position	32
4.2Specified description of mounting position	32
<b>5.Lubrication/Cooling/Heating</b>	36
5.1Lubrication selection	36
5.2Quantity of lubrication oil fill	36
5.3Lubrication oil change	37
5.4Heating	37
5.5Backstop	37
<b>6.Application</b>	38
6.1Fill the lubrication oil	38
6.2Check the device	38
6.3Start	38
<b>7.Checks and maintenance</b>	39
7.1Check and maintenance regularly	39
7.2Periods of checks and maintenance	39
7.3Notes for checks and maintenance	39
<b>8.Fault treatment</b>	40
<b>After-sales service</b>	41

## Important notes

During installation, please pay attention to the safety notes and warning in this book!



Electricity danger  
Possible result: death or serious injury



Dangerous situations  
Possible result: minor injury



Harmful situations:  
Possible result: damage transmission device and the environment



Application suggestions and useful information



If you conform to the regulations in this manual, there won't be any fault, at the same time, it can satisfy the requirements of quality defect claim. So before the transmission device starts working, please read this instruction.

This instruction book contains important installation and maintenance notes, please keep this instruction book in a place near the device for reference.

# 1.Safety information

Safety information mainly involve the applications of gear unit.When running gear unit,please note the relevant notes.

This instruction is an integral part of the gear unit supplied.

All persons involved in the installation, operation,maintenance and repair of the gear unit must have read the instructions and comply with them.

Conforming to the instruction strictly is a necessity for realizing non - fault running and performing any quality assurance requirement.

Under the premise of conforming to instruction, please pay attention to:

National (Local) regulations for relevant safety and accident preventions;

Special regulations and requirements of relevant devices;

Warning and safety mark on device.

The following situations will cause human injury and property loss:

Incorrect running;

Wrong installation or operation;

Dismatle the protect cover or housing against the instructions.

Any damage or stop caused by disregarding this instruction book will not be responsible by the company.

To seek for technical advance, we reserve the rights to modify the instructions. With continuous improvements, we will further improve its performance and safety performances on the foundation of keeping the basic characteristics.

## 2. Technical information

### 2.1 The name plate information

⊕ <b>BONENG</b> ⊕	
Type	
n <sub>2</sub>	RPM
P <sub>1</sub> kW	T <sub>2</sub> N · m
n <sub>1</sub> RPM	i
Oil	Wt. kg
NO.	Date
⊕ ⊕	

Product type

Output speed (only for directly connected motor)

Rated input power kW (it means motor power for directly connected motor)

Rated output torque N · m

Rated input speed RPM(it means motor speed for directly connected motor)

Nominal ratio

Lubrication oil viscosity

Weight

Product number

Production date

Data on nameplate are very important, please read them carefully and keep them clean. When services are needed, please provide the product number, used time and fault details.

## 2.2 Type instruction

### 2.2.1 R Series

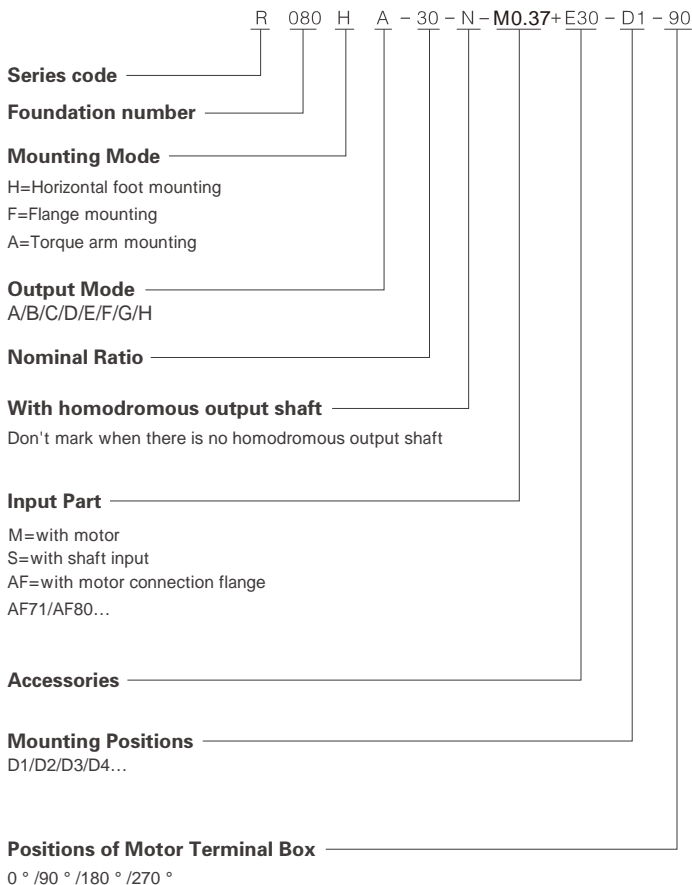

## 2.2.2 J Series

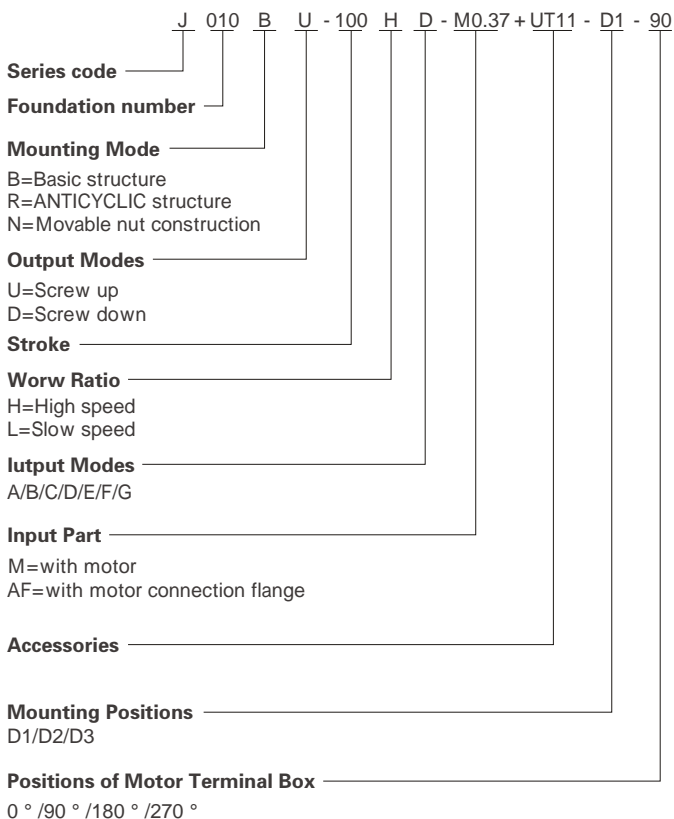

## 2.2.3 T Series

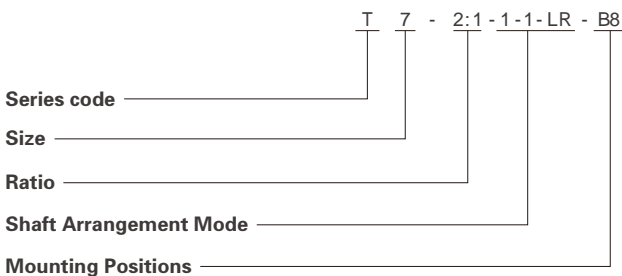

Type designation is only for customer references. For special supply category, please consult;

## 2.3 Noise level

This means noise level of the gear unit when the distance is 1m. Noise level means, when gear unit is under heat engine state, when input speed is  $n_1$ , input power is  $P_1$ . If several numbers are marked at the same time, the highest speed and power will be applied. Noise power level can be seen in table 1.

Table 1 Noise power level

Unit : dB(A)

Motor level	R	J	T
4、 6、 8level	73	72	73

## 2.4 Temperature rising

Temperature rise produced during running of gear unit should not be larger than the regulations in table 2, highest temperature of oil tank should not exceed 90 .

Table 2 Temperature rise of oil tank

Unit :

Motor level	Loading form	R	J	T
4,6,8 level	Empty loading	42	40	42
	Loading	44	42	44

## 2.5 Notes (Following notes are related to the use of gear units)

When conveying gear unit, prevent colliding shaft end, when hoisting gear unit, the hanging ring bolt should not be hung on screw of shaft end.

When storing gear unit and any unique component, take anti - rust measures, prevent rusts; When storing it, the components should not be piled together with gear unit; the gear unit should be laid on dry wooden foundation with no vibration, take dust and water prevention measures.

For gear units with long storage time (one to two years), with regular package check, you should also check cleanness of the machine, the completeness of mechanical damage and anti - rust layer.

The gear unit should not be stored or should not work in environments with acid and alkaline, low temperature, high temperature, damp or heavy air pollution. (except for the ones specially regulated in order).

Working environment of the gear unit should not be higher than 40 , temperature rise should be lower than 50 . (except for the special regulations in order).

The gear unit should be used in allowable torque range, if the torque is exceeded, install safety device on output shaft to reduce damage of the gear unit.

The gear unit is appropriate for continuous running (except J series jack), it allowed positive and negative running (except the ones with backstop).

If the mounting direction changes, change oil lens, oil plug, ventilation cap.

The gear unit should not be cleaned with high pressure cleaning equipment.

Installation, maintenance and repair to gear unit should be done when the gear unit is not working.

If there is any abnormal situation during running of the gear unit (for example, overheating or abnormal noise, etc), stop the machine immediately to check, contact with Boneng if necessary.

Welding should not be done on gear unit, it can't be used as joint for welding. Welding will caused irreparable damage to fine tooth and bearings.

The rotating components should be equipped with appropriate protection cover to prevent accident contact of staffs. For example, coupler, fluid coupling, gear wheel, driving belt wheel, etc.

Conform to the additional instructions on gear unit, for example, warning brand on brand, arrow indicating direction, etc; these brands and marks should not have dust and paint on them.

During assembling or disassembling work, the broken bolts should be changed with bolts with the same strength and category.

According to operation condition of the gear unit, the surface, lubrication oil and components of gear unit may reach high temperature, prevent burning.

When changing lubrication oil, be careful, avoid being burnt by hot oil.

When installing J jack, bore on bench surface should be as small as possible under the premise that the screw rod can pass through.

J jack can ' t make continuous running, loading time should not exceed 20%ED (working loading time rate);

When the jack is making normal loading work, it can't be stopped manually, otherwise, the jack maybe seriously damaged;

Components and spare parts should be bought from Boneng, avoid running danger and unnecessary mechanical damage caused by installation of accessories of other companies;



## 3. Installation and dismantlement

### 3.1 Notes before installation



Confirm the gear unit is in good condition (no damage during transporting or storing);

Confirm site environment condition the same with nameplate;

Standard environment temperature of gear unit:  
-10 - +40 ; no oil, acid, harmful gas, steam, radioactive substances, etc;

Gear unit of special form: be allocated according to environment condition;



When installed outdoor, avoid direct sunshine, avoid concentration of heat which may influence normal performances of the gear unit;

Worm gear unit: you can't impose large reversed external inertia moment to the gear units with self-locking functions, avoid damaging gear unit;

### 3.2 Preparations

Completely clean the preservatives, dirt, etc on the surface of input shaft and flange; avoid the solvent from immersing and damaging oil seal;

If the gear unit is stored for more than one year, the lifespan of lubrications in bearing will shorten;

Preparation of tools/materials: a group of spanners, torque spanner, assembly clamp, input and output fixing device, lubricants (anti-rust oil), medium for sealing bolts (screw lock);

### 3.3 Installation of gear unit

The gear unit can only be installed on flat, damping, rigid, torsion resistant supporting structure; at the same time, the parts being installed will not be moved even under maximum loading.

Central height should be correctly aligned during foot-mounted ; coaxiality should be calibrated when coupling connect; run-out should keep within permissible values when flexible coupling connect, while rigid coupling connect ; contour and position tolerance should be guaranteed. And when long coupling, rigidity of shaft should be enough.

correct

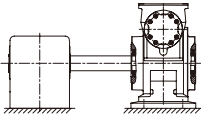

Gear units central height is on the same level with driven machine central height

incorrect

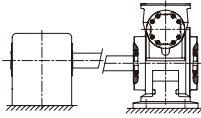

Gear units central height isn't on the same level with driven machine central height

incorrect

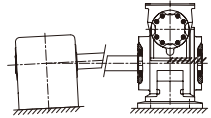

Mounting surface is not on the same level between the driven machine and gear unit.

Press the adapting piece into the shaft end threaded hole by suitable lifting device, knock should be



Correct

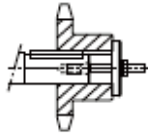

Incorrect

Avoid unallowable radical force (belt wheel, chain installation):

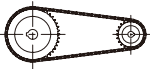

Incorrect

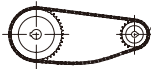

Correct

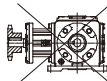

Incorrect

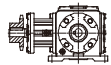

Correct

Avoid un-uniformed loading;

Correct

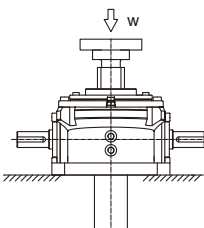

Incorrect

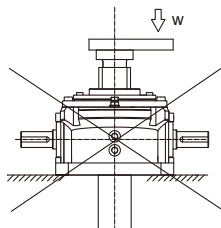

When installing the coupling, make absolutely certain that the following points are accurately aligned :

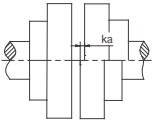

a ) Axial misalignment

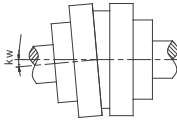

b ) Angular misalignment

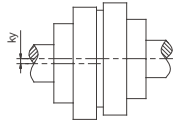

c) Radial misalignment

Flange - mount installation. Protruding (or concave) steps should inosculate with the housing:

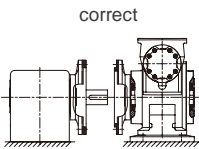

Connection parts should be coaxial.

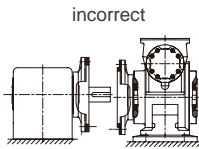

coupling is not coaxial with flange

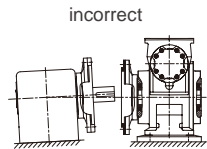

Flange mounting surface is not vertical with the connect shaft.



If you first paint lubricant on output parts, or heat to 80 to 100 in short time, you can assemble easily.

When installing driving components on gear unit (for example, couplings, gear wheel, chain, etc), if pre - heating is needed, you should protect oil sealing on shaft, reduce thermal radiation with heat shielding screen.



Belt wheel, small wheel and couplings can't be covered on shaft end with hammer clicking, otherwise, bearing, cover and shaft may be damaged; Please assemble with clamp and the central holes with threaded hole.

When installation belts, please pay attention to the right tension of the belt. (according to regulation of the anufacturer)

### 3.4 Assembly of hollow shaft of gear unit

When hollow shaft is connected with solid shaft, clean and put anti-rust oil (hollow shaft must be exactly aligned with the machine shaft). Instead of the nut and threaded spindle shown in the diagram, other types of equipment such as a hydraulic lifting equipment can be used.

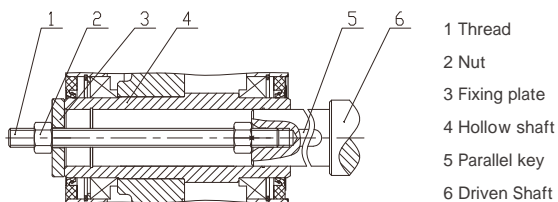

- 1 Thread
- 2 Nut
- 3 Fixing plate
- 4 Hollow shaft
- 5 Parallel key
- 6 Driven Shaft

Generally fixing bolts adopt 8.8 level, in case of high temperature or vibration impact, please take anti-loosening measures on screw joints. The screw torque of each fastening bolt as follows.

Bolt size (mm)	Tighten torque (N · m)	Bolt size (mm)	Tighten torque (mm)
M6	15	M30	2000
M8	36	M36	3560
M10	72	M42	5720
M12	123	M48	8640
M16	295	M56	13850
M20	580	M64	14300
M24	1000	M72	20800



When applying cleaning agent with solvents, you should apply sufficient ventilation measures, you should pay attention to the firing danger of solvents.

Driving and output components, such as belt wheel, couplings, etc should be with contact protection cover plate.

## 3.5 Disassembly of hollow shaft of gear unit

### Disassembly of hollow shaft

Remove the bolt , pressure plate and outer circlip;

Install the assistant plate and the nut between the circlip and the driven shaft , then thread the bolt into the plate to remove driven shaft .

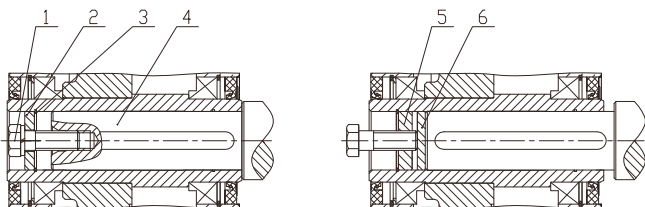

1.Bolt

2.Pressure plate

3.Circlip

4.Driven shaft

5.Nut

6.Assistant plate



Note:

The Assistant plate and the Nut are not in the range of delivery.  
(Arrangement and dimension of screw hole of hollow shaft end can refer to technical diagram of BONENG)





## 4 Mounting position

### 4.1 General description of mounting position

The mounting position details and type selection, please refer BONENG selection manual.

### 4.2 Specified description of mounting position

The symbol of mounting position and its meaning:

Symbol		Meaning	
		Breather	Oil inlet
		Oil ruler	Oil glass
		Oil drain plug	

R050-080 Square housing

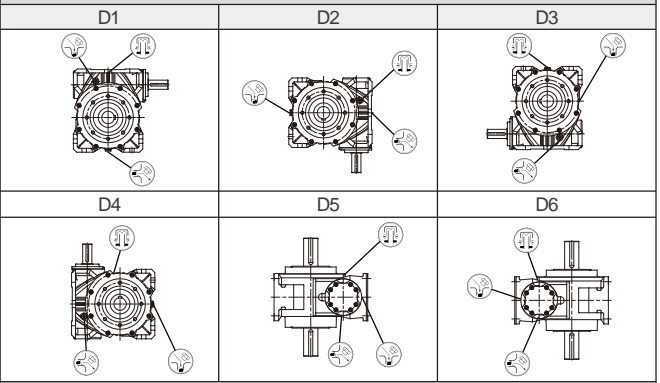

R050-080 Round housing

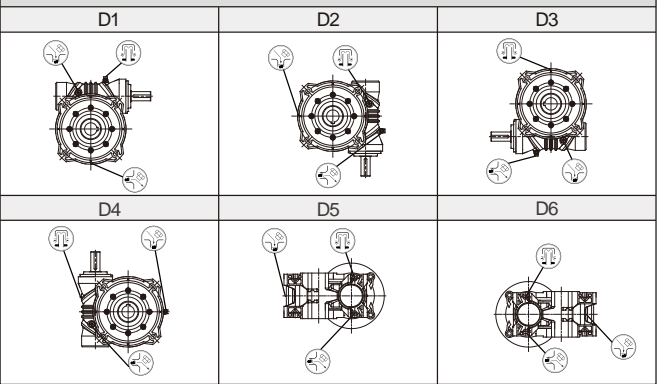

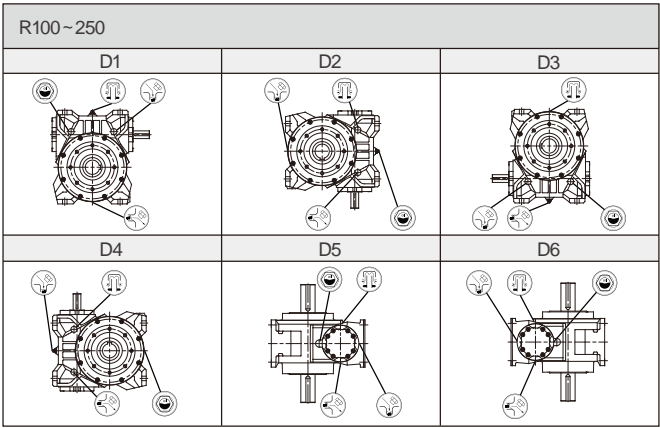

#### 4.2.2 Mounting position of J series screw elevator

J010 - 1000 (J010 - 150 has been filled with extreme pressure lubrication grease, with no oil lens)

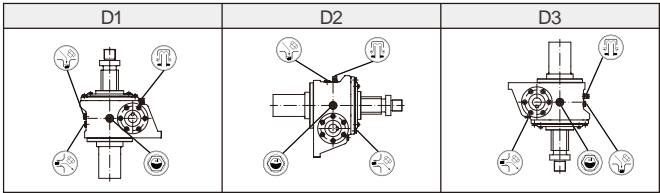

#### 4.2.3 Mounting position of T series bevel gear box

T06 ~ T25 - 1 - .. /U.. /D.. /1 - 1 - .. /U - D.. (ARA1/ARA2/ARA4/T04 has been filled with 000# lithium - based grease when delivered, no oil lens)

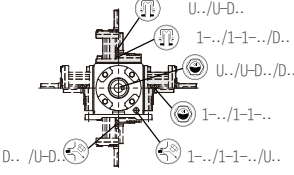
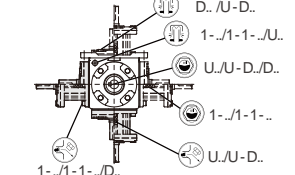
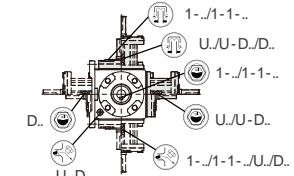
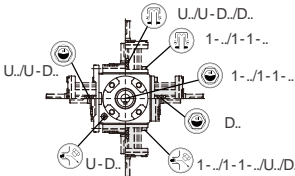
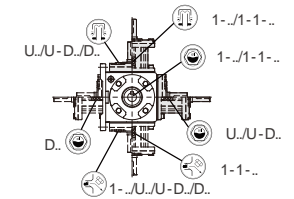
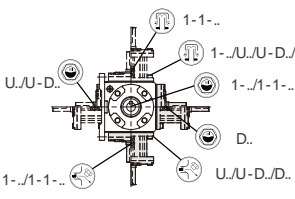
B3	B8
	
B6	B7
	
V5	V6
	



1-LR-..., 1-UD-..., U-LR-..., D-LR-..., 1-1-LR-..., 1-1-UD-..., U-D-LR-... are configuration forms of different kinds of input/ output shafts (each category has 6 kinds, 42 kinds in total)

Customers can select different types according to actual installation requirements, when necessary, consult the technical department of BONENG.



# 5 Lubrication/ Cooling/ Heating

## 5.1 Lubrication selection

Under the premise of the same viscosity level and category, you can choose internationally famous brand. If you need to change the recommended viscosity level, please consult.

Boneng lubrication oil selection are listed in following table

Product series	Applicable product specification	Lubrication oil (grease) brand number	Ambient temperature
R	R050 ~ R080	000# Extreme pressure lubrication grease	-10 ~ +40
	R100 ~ R250	VG680 (worm oil)	-20 ~ +50
T	T01 ~ T04	000# Extreme pressure lubrication grease	-10 ~ +40
	T06 ~ T16	VG220 (heavy loading industrial gear oil)	-20 ~ +40
	T20/T25	VG320 (heavy loading industrial gear oil)	-20 ~ +40
J	J010 ~ J150	000# Extreme pressure lubrication grease	-10 ~ +40
	J200 ~ J1000	VG220 (worm oil)	-20 ~ +40



When ambient temperature is lower than -10 , you have to use synthetic oil.

To ensure lifespan of the products, we recommend synthetic oil.

When ambient temperature exceeds the above range, please consult technical department of BONENG.

## 5.2 Quantity of lubrication oil fill

This quantity is a recommended value. According to the difference of gear unit level and ratio, the oil filling quantity is different. Please pay attention to oil ruler scale as the indication of oil filling. Please refer the oil glass level and fill the oil to the middle level of oil glass.

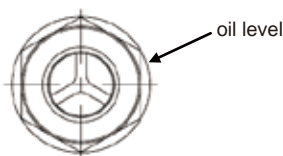

For the products not set or not installed with oil lens, the oil injection quantity should refer to the product sample instruction book.

For products of the same category, under different installation direction, oil injection quantity is not the same.

Following table lists the suggested oil value according to the gearmotor mounting position.

## 5.2.1 R series oil quantity reference (unit: L)

Type Installation position	R050	R063	R080	R100	R125	R160	R200	R250
D1, D3	0.1	0.2	0.38	1	8.1	15	30	51
D2, D4	0.12	0.25	0.46	1.2	10	18	33	57
D5, D6	0.04	0.6	0.12	0.4	3.3	5.5	9.4	17

## 5.2.2 J series of oil filling quantity reference (unit: L)

Type Installation position	J010	J025	J050	J100	J150	J200	J300	J500	J750	J1000
D1, D3	0.1	0.12	0.15	0.22	0.25	0.6	2.5	5.5	9.5	14
D2	0.1	0.12	0.15	0.22	0.25	0.5	2	4.5	7.5	8

Note: Elevator operation process screw(nut) need to grease

## 5.2.3 the T series of oil filling quantity reference (unit: L)

Type Installation position	ARA1	ARA2	ARA4	T04	T06	T07	T08	T10	T12	T16	T20	T25
B3/B8/B6 /B7/V5/V6	Injected	Injected	Injected	Injected	0.95	1.5	1.9	3.5	7	10	11	18

## 5.3 Lubrication oil change

Change oil with the same type and manufactured in the same factory. Before filling the new oil, please clean the sediments, metal particles and remained oil in the housing off.

## 5.4 Heating

For standard gear unit, the working ambient temperature is - 10 ~ +40 °C, when the temperature is under - 10 °C, it needs to be preheated or running without load. When the gear unit temperature is over - 10 °C, gear unit can be operated with load.

## 5.5 Backstop

Gear unit with shrink disc. Before assembly or running, please check the transmission machine running direction. To avoid wrong direction running, if necessary, please consult technical person. Backstop do not need maintenance.

## 6.Application

### 6.1 Fill the lubrication oil

Our products are not filled with lubrication oil when delivered.You should fill lubrication oil according to instruction book before running.



On the position marked with this symbol, fill lubrication oil into gear unit.

### 6.2 Check the device

Check oil level.

For the gear unit equipped with backstop device, inspect whether wiring of motor is correct.

Inspect whether shaft sealing is effective.

Check whether the rotating components contact with other components.

### 6.3 Start

Check whether the running direction under free status is correct (supervise whether there is abnormal grinding noise when the shaft is running).

During running inspection, you should ensure no output component on shaft, open relevant supervision and protection device at the same time.

If there is abnormal running phenomenon (for example, temperature rise, noise, vibration, etc), you should turn off the motor and check out the reason.

Contact with BONENG when necessary.

# 7 Checks and maintenance

## 7.1 Check and maintenance regularly

Users should make regular maintenance to gear unit. Check the status of lubrication oil regularly, clean ventilation cap, fan, cooling coil and the surface of gear unit, keep the gear unit clean, ensure normal running of gear unit.

## 7.2 Periods of checks and maintenance

Check oil temperature	Daily
Check abnormal noise of gear unit	Daily
Check oil level	Monthly
Check gear unit for leaks	Monthly
Check oil for water content	After working 400 hours, at least once a year
First oil change after starting	After working 400 hours
Subsequent oil changes	After every 5000 hours
Clean the breather	Every 3 months
Clean gear unit housing	Do with oil changing
Check tightness of fastening bolts	The first time after changing oil, then change oil every two times
Carry out complete inspection of gear unit	About every 2 years, do with oil changing

## 7.3 Notes for checks and maintenance:

Cut off power source, prevent electric shock, wait for cooling of gear unit.

Inspection of oil level: Please refer the oil glass level and fill the oil to the middle level of oil glass .

Oil inspection: remove oil drain plug, take some samples, inspect oil viscosity index; if the oil is not clean, change it.

Oil changing:

It is forbidden to mix different lubricants.

After cooling, oil viscosity will increase, it is harder to drain off oil. change before cooling.

Put an oil picking plate under oil plug, tear down oil plug ventilation cap, install oil plug after removing oil.

Inject new oil of the same brand, oil quantity should be the same with installation direction (see nameplate); if the brand number is different, consult after - sales department.

Inspect oil level at oil glass, install vent cap.

## 8 Fault treatment

Fault	Reason	Measure
Noise change of gear unit	Fastening is loose	Tighten bolts/nuts to prescribed torque Replace damaged bolts/nuts
	Damage to gear unit	Contact customer service Check all teeth and replace any damaged parts
	Excessive bearing play	Contact customer service Adjust bearing play
	Bearing defective	Contact customer service Replace defective bearings
Operating temperature too high	Oil level in gearmotor housing too high or too low	Check oil level and, if necessary, adjust
	Oil too old	Contact customer service Check date of last oil change if necessary, change
	Oil badly contaminated	Contact customer service Change oil
Increased vibration amplitudes at the bearing points	Bearing defective	Contact customer service Check and, if necessary, replace bearings
	Gear defective	Contact customer service Check gears and, if necessary, replace
Oil leakage from gear unit	Inadequate sealing of housing covers or joints	Check and, if necessary, replace seals, seal joints
	Radial shaft sealing rings defective	Contact customer service Replace radial shaft sealing rings
Water in the oil	Oil foams in sump	Check state of oil by the test - tube method for water contamination. Have oil analysed by laboratory
	Gear unit exposed to cold air from machine - room ventilator	Protect gearmotor with suitable heat insulation. Close air outlet or alter its direction by structural measures



Note: For the faults can't be removed by customers, please contact with after-sales department of the company.

# After-sale service

For the various kinds of transmission devices, if there is any quality problem, don't tear down components, you should illustrate the situation, then contact with after-sales department of the company, confirm about the problems, then apply ideal method to deal with them.

Logging in " www.boneng.com "

Click " Service "

Click " After-sale Service "



**BONENG TRANSMISSION(SHEN YANG)CO.,LTD**

Controller/Drive : 024 - 31271571

Motor/Gear motor/Gearbox : 024 - 31292571

**BONENG TRANSMISSION(TIAN JIN)CO.,LTD**

Controller/Drive : 022 - 86928559

Motor/Gear motor/Gearbox : 022 - 26929558

**BONENG TRANSMISSION(KAIFENG)CO.,LTD**

Controller/Drive : 0371 - 23335230

Motor/Gear motor/Gearbox : 0371 - 23277771

**BONENG TRANSMISSION(WEIFANG)CO.,LTD**

Controller/Drive : 0536 - 4699687

Motor/Gear motor/Gearbox : 0536 - 4699667

**BONENG TRANSMISSION(CHANGSHA)CO.,LTD**

Controller/Drive : 0731 - 88386958

Motor/Gear motor/Gearbox : 0731 - 88380725

**BONENG TRANSMISSION(SUZHOU)CO.,LTD**

Controller/Drive Southern Jiangsu : 0512 - 66182005

Motor/Gear motor/Gearbox Southern Jiangsu : 0512 - 66189918

Controller/Drive Zhejiang - Shanghai : 0512 - 66182005

Motor/Gear motor/Gearbox Zhejiang - Shanghai : 0512 - 66189918

Controller/Drive Jiangsu - Anhui District : 0512 - 66182005

Motor/Gear motor/Gearbox Jiangsu - Anhui : 025 - 52171612

**BONENG TRANSMISSION(USA/Canada)CO.,LTD**

Technical Support/Debugging/After - Sales Service :

1250 E 222nd Euclid, OH 44117, United States

Email: America@boneng.com

Office Tel: 1-216-618-3099 / 1-216-618-0138

**BONENG TRANSMISSION(India)CO.,LTD**

Technical Support/Debugging/After - Sales Service :

Plot No. E - 10/3, MIDC sinner (Malegaon) Industrial Area,

Nashik, 422123, Maharashtra, India.

Email: india@boneng.com

Tel: +91 - 22 - 2781 3385 / +91 - 11 - 4507 6293

**Other District**

Controller/Drive : 0512 - 66182005

Motor/Gear motor/Gearbox : 0512 - 66189918

**BONENG**